

Kinyarwanda locative applicatives and the Minimal Link Condition

Jochen Zeller* and Jean Paul Ngoboka

Department of Linguistics, University of KwaZulu-Natal, Durban 4041, South Africa

* Corresponding author, e-mail: zeller@ukzn.ac.za

Abstract: The two objects of ditransitive locative applicatives in Kinyarwanda display asymmetrical behaviour with respect to syntactic movement. Whereas the applied object (the goal) of a locative can be extracted in relative clauses, become the subject of a passive and incorporate as an object marker, the theme cannot undergo any of these operations, at least not as long as the applied object remains in object position. However, once the applied object has been passivised, relativised or incorporated, the theme is also free to move. We analyse these observations on the basis of the Minimal Link Condition (MLC) (Chomsky, 1995; 2000), which excludes movement of an element α to a position K if there is another element β of the same type which is closer to K. We show that the theme cannot move in Kinyarwanda locative applicatives because the applied object is closer to the potential landing site. However, in contexts in which the applied object has been moved ‘out of the way’, the MLC no longer blocks movement of the theme. In our analysis, we discuss a number of key theoretical concepts of the Minimalist Program, such as the Extension Condition, the notion of minimal domain, and derivation by phase.

Introduction

In this paper, we discuss locative applicative constructions in Kinyarwanda, a Bantu language spoken in Rwanda and its neighbouring countries (Kimenyi, 1980; Ngoboka, 2005). Specifically, we are concerned with contrasts such as the one between (1b) and (1c) in the locative example (1) below.¹ (1a) depicts a locative applicative which has been derived from the verb *teera*, ‘throw’, by means of the suffix *-ho*. The locative takes two DP-

objects, the theme argument *amabuye*, ‘stones’, and the locative/goal argument *inzu*, ‘house’ (henceforth the ‘applied object’). As is illustrated by (1b), locative applicatives do not allow passivisation of the theme if the applied object is a full DP adjacent to the verb. However, (1c) shows that the theme DP can be passivised once the applied object is realised as an object marker (in italics) on the verb.

Example 1

-
- | | |
|------|---|
| (1a) | Umujuura y-a-tee-ye-ho inzu amabuye
thief SP-PST-throw-ASP-APPL house stones
‘The thief threw the stones on the house’ |
| (1b) | *Amabuye y-a-tee-w-e-ho inzu n’umujuura
stones SP-PST-throw-PASS-ASP-APPL house by thief
‘The stones were thrown on the house by the thief’ |
| (1c) | Amabuye y-a-yi-tee-w-e-ho n’umujuura
stones SP-PST-OM-throw-PASS-ASP-APPL by thief
‘The stones were thrown on it by the thief’ |
-

In the next section, we present more data from locative applicatives which show that not only passivisation but also extraction and object marking of the theme are excluded in Kinyarwanda, unless the applied object has itself either been passivised, extracted or object-marked. We suggest that this situation follows from the Minimal Link Condition (MLC), which is the main locality constraint for syntactic movement operations in the Minimalist Program (Chomsky, 1995; 1999; 2000; 2001). The MLC blocks movement of an element if there is another element with a similar feature specification which is closer to the potential landing site. We claim that the theme cannot move to the subject position in examples such as (1b) because the applied object is closer to this position than the theme. However, in contexts in which the applied object has been moved 'out of the way' (which is the case, we argue, in examples such as (1c), where the applied object is an object marker), the MLC no longer blocks movement of the theme.

We outline the details of this proposal in the two sections that follow. Our analysis is based on various aspects of the studies of Kinyar-

wanda locatives presented in Baker (1988; 1992), Nakamura (1997) and McGinnis (2001; 2004), but also incorporates some of the core ideas presented in Anagnostopoulou's (2003) theory of ditransitives. In the third section, we suggest that in ditransitive locative applicatives, both objects of the verb move to a specifier of a functional category Asp. Crucially, we claim that the applied object always moves to the higher specifier position from where it c-commands the theme in the lower specifier. In this configuration, the applied object is therefore closer to any potential landing site and, consequently, the MLC blocks movement of the theme across the applied object. The fourth section offers a detailed discussion of examples such as (1c), in which movement of the applied object obviates the effects of the MLC and makes movement of the theme possible. Finally, the fifth section of this paper compares locative applicatives to those types of applicatives in Kinyarwanda in which contrasts like the one exhibited by (1) are absent. The last section concludes the article with a few comments on applicatives in Bantu languages other than Kinyarwanda.

Examples 2–5

-
- (2) Umubooyi y-a-menn-ye-ho umwaana amaazi
 cook SP-PST-pour-ASP-APPL child water
 'The cook poured water on the child'
- (3a) Umwaana y-a-menn-w-e-ho amaazi n'umubooyi
 child SP-PST-pour-PASS-ASP-APPL water by cook
 Lit.: 'The child was poured on the water by the cook'
- (3b) *Amaazi y-a-menn-w-e-ho umwaana n'umubooyi
 water SP-PST-pour-PASS-ASP-APPL child by cook
 'The water was poured on the child by the cook'
- (4a) Umubooyi y-a-*mu*-menn-ye-ho amaazi
 cook SP-PST-OM-pour-ASP-APPL water
 'The cook poured water on him/her'
- (4b) *Umubooyi y-a-*ya*-menn-ye-ho umwaana
 cook SP-PST-OM-pour-ASP-APPL child
 'The cook poured it on the child'
- (5a) umwaana umubooyi y-a-menn-ye-ho amaazi
 child cook SP-PST-pour-ASP-APPL water
 'the child on whom the cook poured water'
- (5b) *amaazi umubooyi y-a-menn-ye-ho umwaana
 water cook SP-PST-pour-ASP-APPL child
 'the water which the cook poured on the child'
-

Object properties in Kinyarwanda locatives

The two DP-objects of ditransitive locative applicatives in Kinyarwanda display well-studied asymmetrical behaviour with respect to passivisation, object marking and extractability. Generally, only the applied object of a locative applicative can be subject to these operations and thus shows what Bresnan and Moshi (1990) call 'primary object properties'.² As is shown in (3), whereas the applied object of the locative in (2) can be passivised, (3a), passivisation of the theme is excluded, (3b); see also (1b) above.

Similar contrasts emerge with respect to object marking. Although the applied object can be realised as an object marker, (4a), object marking of the theme is not possible in locatives, as in (4b).

Finally, whereas the applied object in Kinyarwanda locatives can be extracted in relative clause constructions like (5a), theme extraction is blocked in (5b).

The contrast between the properties of the applied object and the theme in Kinyarwanda locatives has been the topic of various studies (e.g. Baker, 1988; 1992; Marantz, 1993; Naka-

mura, 1997; McGinnis, 2001). However, a fact about Kinyarwanda which has often been overlooked or ignored in these studies is that the theme *can* adopt primary object properties *in certain contexts*. Note that in all the ungrammatical (b)-examples in (3) to (5), the applied object is realised as a full DP-object and appears adjacent to the verb. However, it is an interesting fact about Kinyarwanda applicatives that in those contexts where the applied object has itself been extracted, passivised or object-marked, these operations are also available for the theme. (6a) illustrates that, in contrast to (3b), passivisation of the theme is possible once the applied object is an object marker; see also (1c). Moreover, the theme can also be passivised once the applied object has been extracted in a relative clause construction, as in (6b).

Similarly, (7) shows that, in contrast to (4b), object marking of the theme is possible if the applied object is also an object marker, as in (7a), or if it has been extracted, as in (7b) or passivised, as in (7c).

Finally, although theme extraction is ruled out in examples such as (5b), the theme can be extracted once the applied object is

Examples 6–8

-
- (6a) Amaazi y-a-mu-menn-w-e-ho n'umubooyi
water SP-PST-OM-pour-PASS-ASP-APPL by cook
'The water was poured on him/her by the cook'
- (6b) umwaana amaazi y-a-menn-w-e-ho n'umubooyi
child water SP-PST-pour-PASS-ASP-APPL by cook
'the child on whom the water was poured by the cook'
- (7a) Umubooyi y-a-ya-mu-menn-ye-ho
cook SP-PST-OM-OM-pour-ASP-APPL
'The cook poured it on him/her'
- (7b) umwaana umubooyi y-a-ya-menn-ye-ho
child cook SP-PST-OM-pour-ASP-APPL
'the child on whom the cook poured it'
- (7c) Umwaana y-a-ya-menn-w-e-ho n'umubooyi
child SP-PST-OM-pour-PASS-ASP-APPL by cook
Lit.: 'The child was it poured on by the cook'
- (8a) amaazi umubooyi y-a-mu-menn-ye-ho
water cook SP-PST-OM-pour-ASP-APPL
'the water that the cook poured on him/her'
- (8b) amaazi umwaana y-a-minn-w-e-ho n'umubooyi
water child SP-PST-pour-PASS-ASP-APPL by cook
Lit.: 'the water which the child was poured on by the cook'
-

realised as an object marker or when it has undergone A-movement in a passive; see (8).

Most existing analyses of which we are aware are merely concerned with the lack of the theme's primary object properties in constructions such as (3b) to (5b), and hence do not offer an analysis of those constructions in which the theme does have these properties. For example, Baker (1988; 1992) and Nakamura (1997) assume that the contrasts exhibited in (3) and (4) are case-related. They argue that the applied object in a locative applicative has structural case, but that the theme has inherent case. Given the standard assumption that only structural case is absorbed in passives and that only objects with structural case can be realised as object markers, it follows that passivisation and object marking are not possible with the theme. However, what Baker's and Nakamura's analyses do not explain is why passivisation and object marking of the theme become possible when the applied object is an object marker, a relative operator or the subject of a passive.

McGinnis' (2001) analysis of Kinyarwanda applicatives assumes that object marking of the theme is contingent on an EPP-feature associated with a functional applicative head. Crucially, McGinnis suggests that in Kinyarwanda locatives, the applicative head does not have an EPP-feature. Although this assumption accounts for why the theme in examples such as (4b) cannot be realised as an object marker, it does not explain why object marking becomes possible when the applied object is passivised, extracted or also object-marked.

Another shortcoming of these existing analyses is that the contrasts in (3) to (5), although clearly of a similar nature, are often

explained by different mechanisms. For example, whereas Nakamura (1997) excludes *passivisation* and *object marking* of the theme through principles of case theory, the impossibility of theme *extraction* cannot be explained through case, since extractability is not connected to the case properties of a phrase. Therefore, the explanation that Nakamura provides for the contrast in (5) differs from his explanation for the contrasts in (3) and (4).³ We consider this an unwelcome result, not only because the data in (3) to (5) exhibit a similar pattern, but also in the light of the data in (6) to (8), which show that theme extraction, object marking and passivisation become possible under exactly the same conditions (namely, when the applied object has been 'moved away').

In view of these comments, we will attempt to provide a uniform analysis of the contrasts in (3) to (5) which also explains the data in (6) to (8). In contrast to Baker (1988; 1992), Marantz (1993) and Nakamura (1997), we argue that the theme's lack of primary object properties is not due to its failure to get structural case.⁴ Rather, we follow Ura (1996), McGinnis (1998; 2001; 2004), Anagnostopoulou (2003) and others in assuming that the relevant asymmetries observed in double object constructions are generally the result of the violation of locality constraints. More specifically, we suggest that theme passivisation, pronominalisation and extraction in Kinyarwanda applicatives are blocked by the MLC (Chomsky, 1995; 1999; 2000). The definition of the MLC is given in (9) below.

In the Minimalist Program (henceforth MP), movement of constituents is assumed to be *feature-driven*. Formal features associated with functional heads in the syntactic represen-

Examples 9–11

-
- (9) The MLC (Chomsky, 1995: 311):
K attracts α only if there is no β , β closer to K than α , such that K attracts β
- (10) Closeness (Chomsky, 1995: 358; Sabel, 2002: 273):
 β is closer to the target K than α if β c-commands α
- (11a) [C you wonder [_{CP} which car John could fix t how]?
- (11b) *How do you wonder [_{CP} which car John could fix t t]?
-

tation need to be matched with the corresponding formal features of lexical items. The relevant target features of a Category K locate the matching features associated with an element α . K then attracts α , which moves and enters a checking configuration in which the features of K and α can be matched. As a result of feature matching, the features of the target are deleted.⁵ Importantly, the MLC prevents α from moving if there is a closer β such that K attracts β .

To illustrate how the MLC works, consider the familiar example of a wh-island effect in (11) (see Chomsky, 2000; Sabel, 2002). Both C-heads in (11) have a [Q]-feature which needs to be matched with the [Q]-feature of a wh-phrase. In (11a), the wh-phrase *which car* has moved to the embedded SpecC position to check the [Q]-feature of the embedded C. The [Q]-feature of the matrix C still needs to be checked. In (11b), it is matched with the [Q]-feature of the wh-phrase *how*, which has moved to matrix SpecC. However, since the wh-phrase *which car* c-commands *how* and is therefore closer to the matrix C, (11b) violates the MLC and is therefore ungrammatical.

We adopt the definitions in (9) and (10) with one important addendum. We assume that if a feature is associated with a head X^0 , then XP only attracts β if β is outside X^0 's *minimal*

domain (= the complement and specifier of X^0 , plus all nodes dominated by X^0 if X^0 is complex; see Chomsky, 1995: 178).⁶ This strikes us as a natural assumption; if attraction is motivated by feature checking in a local environment, then elements which are already in a local environment of a head cannot be attracted.⁷ It then follows from (9) that an element β which is in X^0 's minimal domain does not prevent XP from attracting α , even if β c-commands α . This is shown in the diagram in (12). (12) illustrates that an element α can target XP and move across β if β is part of X^0 or in SpecX. In the latter case, α moves across the c-commanding β in the first SpecX and forms a second specifier above β . Notice that, if β is part of X^0 , it does not c-command α (see Chomsky, 2000: 117); therefore, according to the definition in (10), β would not be closer to any potential target than α , and movement of α across β is allowed anyway.

Our analysis, which we discuss in detail in the next sections, presumes that the ungrammatical examples in (3) to (5) are ruled out as violations of the MLC. We argue that (i) extraction, passivisation and object marking involve formal features of functional heads that attract corresponding features associated with the theme and the applied object, and that (ii) the applied object c-commands the theme at the relevant stage of the derivation and is therefore always closer to the attracting category. Movement of the theme in e.g. passives is therefore blocked by the presence of the applied object in the same way as movement of the wh-phrase *how* in (11b) is blocked by the presence of the c-commanding wh-phrase *which car*.

However, notice that the blocking effect of a phrase intervening between an attractor and its target disappears once the phrase is moved 'out of the way'. According to Chomsky (1999:

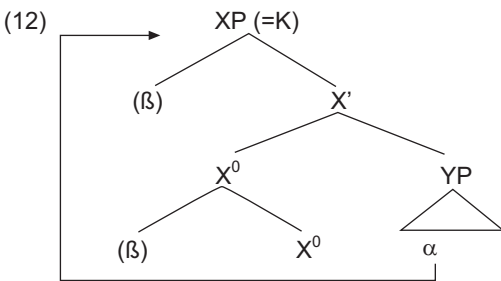

Example 13

- (13a) *Elle_i semble au garçon [t_i avoir du talent]
 she seems to the boy have talent
 'She seems to the boy to have talent'
 (13b) À qui_i semble-t-elle_i t_j [t_j avoir du talent]?
 to who seems she have talent
 'To whom does she seem to have talent?'

(French)

22), the trace (or copy) of an XP never blocks attraction of a phrase it c-commands in terms of the MLC, because the trace/copy of XP is not phonetically realised. This assumption explains, among other things, the contrast in (13) (from McGinnis, 2001). In (13a), the experiencer *au garçon* c-commands the SpecT-position of the infinitive. Therefore, raising of the embedded subject to matrix SpecT violates the MLC. In contrast, the experiencer has been moved to SpecC in (13b), and its invisible trace does not block DP-movement of the embedded subject. Therefore, (13b) is grammatical.

On the basis of Chomsky’s claim, the data in (6) to (8) can be explained as follows: when the applied object has itself been passivised, incorporated or extracted, only its phonetically unrealised copy intervenes between the theme and an attracting feature. In these contexts, the applied object no longer induces a blocking effect in terms of the MLC, and the theme can therefore be moved.

Structural case and multiple specifiers

As our starting point, we assume that non-applied constructions such as (14a) and the corresponding locative applicative in (2) — repeated here as (14b) — are based on a structure like (15).

(15) is adopted from Nakamura (1997), whose analysis of applicatives is based on Baker’s (1988; 1992) influential incorporation analysis. Baker argues that the thematic relations between the verb, the theme and the goal argument in a locative applicative such as (14b) are identical to the thematic relations in a non-applied construction such as (14a) and therefore have to be represented through identical syntactic relations (the Uniformity of Theta Assignment Hypothesis: see Baker,

1988). Therefore, the goal object in both (14a) and (14b) is merged into the structure inside a PP-complement of the verb, while the theme is located in SpecV (see also Larson, 1988 for arguments). However, whereas the preposition in (14a) is the free morpheme *ku*, the head of the PP in the locative applicative in (14b) is the applicative morpheme *-ho*, which, according to Baker (1988), is an affixal preposition. As an affix, *-ho* needs a host and therefore incorporates into the verb in locative applicatives.

The VP in (15) is selected by Asp; structural case is checked in SpecAsp (see also Marantz, 1993; Baker, 1997). AspP is selected by Pr, the head of a predicate phrase (Bowers, 1993) which introduces the external argument in SpecPr. PrP merges with T, the head of TP; TP merges with C (this part of the structure has been omitted in (15)).

As argued in Jaeggli (1986) and Baker (1988), Kinyarwanda verbs have the ability to

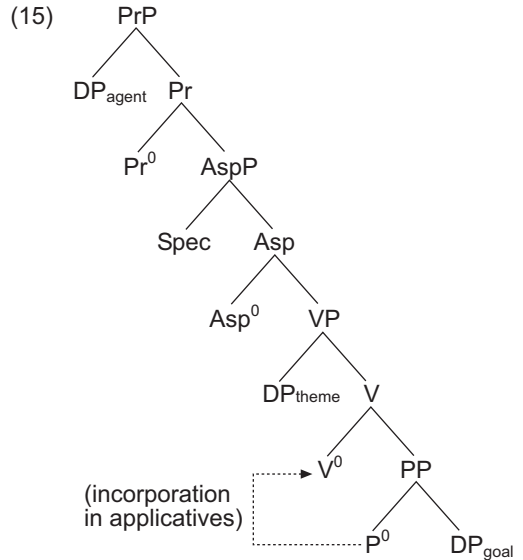

Example 14

(14a) Umubooyi y-a-menn-ye amaazi ku mwaana
 cook SP-PST-pour-ASP water on child
 ‘The cook poured water on the child’

(14b) Umubooyi y-a-menn-ye-ho umwaana amaazi
 cook SP-PST-pour-ASP-APPL child water
 ‘The cook poured water on the child’

assign structural case to two objects. Translated into the case-checking theory of the MP, this means that Asp in Kinyarwanda can optionally attract two object DPs with structural case features. Consequently, Asp in Kinyarwanda can project *multiple specifiers*. We also assume that Asp in Kinyarwanda can host an EPP-feature, which is checked by a DP in the highest specifier (cf Chomsky, 2000).⁸ In these respects, Asp in our analysis is comparable to the functional category ApplH ('high applicative') in McGinnis' (2001; 2004) theory, which also projects multiple specifiers. However, McGinnis assumes explicitly that locative applicatives are not associated with ApplH, but rather with the category ApplL ('low applicatives'), which does *not* project multiple specifiers in her theory.⁹ In contrast to McGinnis, we argue that the availability of two specifier positions in which structural case can be checked is a crucial aspect of the structure of locative applicatives in Kinyarwanda, and that the data discussed above follow from this important fact.

Since the applicative affix incorporates into the verb in locative applicatives, and given that traces cannot assign case to their complements (see Baker, 1988; 1992), the applied object in a locative applicative cannot get case in the complement position of P. We follow Nakamura and assume that, therefore, the applied object (the goal) must move to SpecAsp to check its structural case feature against the corresponding ϕ -features of Asp. However, we depart from Nakamura's analysis with respect to the case properties of the theme. Whereas Nakamura assumes that a theme DP in SpecV can be marked with inherent case, we maintain instead that inherent case can never be assigned to SpecV. Instead, we suggest that the theme is also equipped with a structural case feature which needs to be checked in SpecAsp. This means that both object DPs in locative applicatives are marked for structural case, and Asp

always projects both specifiers to which the two objects move in order to check their respective case features.

Importantly, the order in which the two objects move to SpecAsp is determined by the MLC. Since the theme c-commands the applied object in (15), movement of the applied object across the theme is ruled out. Therefore, the theme always has to move first, projecting the first (lower) specifier of Asp and checking its structural case feature against the relevant ϕ -features of Asp. However, once the theme has moved to SpecAsp, the MLC no longer blocks attraction and feature-driven movement of the applied object, because the copy of the theme in SpecV is not phonetically realised and the theme DP itself cannot be attracted, since it is now in the same minimal domain as the head of the attracting category Asp; compare (12). Therefore, the applied object also moves and merges with AspP above the theme, projecting a second (higher) specifier; see (16).

Notice that in our analysis the applied object *must* project the higher SpecAsp; it cannot merge into the tree below the theme. This follows from the extension condition (Chomsky, 1995; 2000; 2001), which implements strict cyclicity into the MP by requiring that substitution operations¹⁰ always extend the phrase structure (see Kitahara, 1995; Bobaljik & Brown, 1997). Chomsky (1995) states the extension condition as in (17), where 'GT' stands for 'Generalised Transformation' (or Merge) which targets a phrase marker K.

We assume that the extension condition also holds for movement operations that

Example 17

Extension Condition (Chomsky, 1995: 190):
GT and Move α extend K to K*, which includes K as a proper part

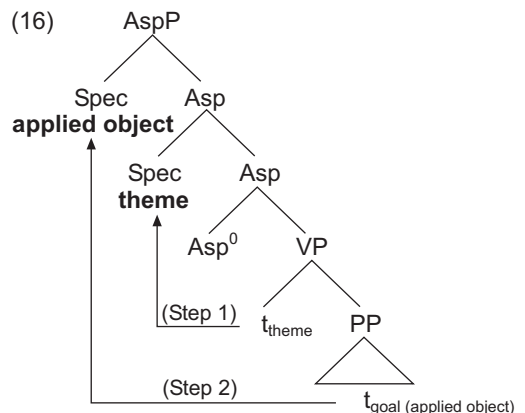

create two specifiers of the same head (the ‘strong extension condition’; see Chomsky, 2001: 6); this assumption rules out ‘tucking in’ processes in the sense of Richards (1997).¹¹ Clearly, if the applied object targetted AspP but moved into a specifier below the theme, then the derived phrase marker K* (the ‘new’ AspP) would not include K (the ‘old’ AspP) as a proper part. Therefore, (17) forces the applied object to move to the higher specifier of Asp.

The extension condition and the MLC explain that locative applicatives have a rigid word order. (18) shows that, in contrast to other types of applicatives in Kinyarwanda (discussed below), the applied object obligatorily precedes the theme in locative applicatives. Since the theme has to move first because of the MLC, and since the applied object has to move to the higher SpecAsp because of (17), the word order in (18b) cannot be derived.

Crucially, the applied object (asymmetrically) c-commands the theme in (16). As is emphasised in Anagnostopoulou (2003), it is this configuration that makes it possible to account for the asymmetrical behaviour of the theme and the applied object in double object constructions in terms of locality, since the applied object is closer to any potential landing site than the theme. In the next section, we show how this locality approach explains the data discussed in the preceding section.

Movement from SpecAsp and the MLC Passivisation of the theme

In this section, we discuss passivisation of the theme in Kinyarwanda locatives. As was shown in (3b) and (6) above, the theme of a locative applicative cannot be passivised, unless the applied object is an object marker or has been extracted. The relevant data are repeated in (19).

Our analysis is based on the structure in (20), a passive construction, with no external argument in SpecPr. The strong EPP-feature of T needs to be checked against the interpretable D-feature of a DP. We implement Burzio’s generalisation (Burzio, 1986) by assuming that in a passive construction, the structural case feature of one of the two DPs in SpecAsp remains undeleted after checking the corresponding ϕ -features of Asp (cf Nakamura, 1997; Chomsky, 2000). In Chomsky (2000), it is argued that DPs

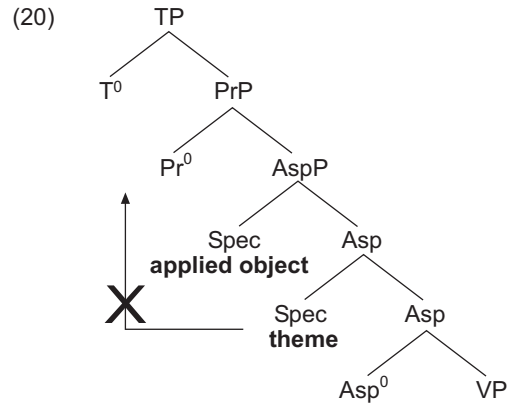

Example 18–19

(18a)	Umubooyi y-a-menn-ye-ho	umwaana amaazi
	cook SP-PST-pour-ASP-APPL child	water
	‘The cook poured the water on the child’	
(18b)	*Umubooyi y-a-menn-ye-ho	amaazi umwaana
	cook SP-PST-pour-ASP-APPL	water child
	‘The cook poured the water on the child’	
(19a)	*Amaazi y-a-menn-w-e-ho	umwaana n’umubooyi
	water SP-PST-pour-PASS-ASP-APPL child	by cook
	‘The water was poured on the child by the cook’	
(19b)	Amaazi y-a-mu-menn-w-e-ho	n’umubooyi
	water SP-PST-OM-pour-PASS-ASP-APPL	by cook
	‘The water was poured on him/her by the cook’	
(19c)	umwaana amaazi y-a-menn-w-e-ho	n’umubooyi
	child water SP-PST-pour-PASS-ASP-APPL	by cook
	‘the child which the water was poured on by the cook’	

with undeleted structural case features remain active and can undergo further movement. Therefore, one of the two object DPs can be attracted by the EPP-feature in T in passive constructions.¹²

If the theme's structural case feature is deleted, then the applied object remains active and can move to SpecT in a passive construction. However, suppose the structural case feature of the applied object in the higher SpecAsp is deleted, but the theme's case feature is not. Then the theme would remain active and could be attracted by T. However, since the applied object occupies the higher SpecAsp, movement of the theme DP would violate the MLC. Notice that according to Chomsky (1999: 22), inactive DPs still induce intervention effects; therefore, the applied object, although inactive, is still a potential target for T's EPP-feature and thus blocks movement of the theme. Therefore, constructions such as (19a) are ungrammatical; see (20).

Now let us turn to the question of why the theme can move to SpecT when the applied object is an object marker or has been extracted. In most generative analyses, object marking in Bantu languages is analysed as object agreement (see e.g. Baker, 1988; 1992; Marantz, 1993; Nakamura, 1997; Woolford, 2000; McGinnis, 2001). However, (21) shows that in Kinyarwanda, an object marker on the verb and the corresponding full object DP cannot co-occur, which renders an agreement

analysis implausible.

Therefore, we adopt the alternative view and follow Kimenyi (1980; 1995) in assuming that object markers in Kinyarwanda, as in many other Bantu languages, are *incorporated pronouns* (see also Bresnan & Mchombo, 1987 for Chichewa; Bresnan & Moshi, 1990; Moshi, 1998 for KiChaga). We analyse object markers as pronominal clitics of Category D which undergo head movement and adjoin to Pr in order to check a gender feature associated with this functional head (cf Anagnostopoulou, 2003). The object clitic incorporates into the verb in Pr and moves with Pr (which includes the verb complex) to T. Furthermore, we assume that pronominal DPs have structural case features which must be checked and deleted in SpecAsp before incorporation takes

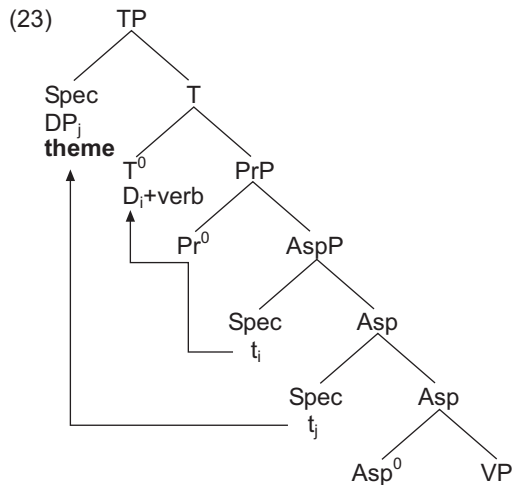

Examples 21–22

- | | | | |
|-------|---|--------------|-----------------|
| (21a) | Umuhiinzi a-ra-saaruur-a | ibishyiimbo | |
| | farmer SP-PRES-harvest-FV | beans | |
| | 'The farmer is harvesting the beans' | | |
| (21b) | Umuhiinzi a-ra-bi-saaruur-a | | |
| | farmer SP-PRES-OM-harvest-FV | | |
| | 'The farmer is harvesting them' | | |
| (21c) | *Umuhiinzi a-ra-bi-saaruur-a | ibishyi imbo | |
| | farmer SP-PRES-OM-harvest-FV | beans | |
| | 'The farmer is harvesting the beans' | | |
| (22a) | ?*To vivlio charistike | tis Marias | apo ton Petro |
| | the book award-PASS | the Mary | from the Petros |
| | 'The book was awarded to Mary by Peter' | | |
| (22b) | To vivlio tis | charistike | |
| | the book OC | award-PASS | |
| | 'The book was awarded to her' | | |

place, since they otherwise would remain unchecked. This proposal implements the common assumption that object marking is only possible if the pronominal clitic has been located in a structural case-checking (or -assigning) specifier position at some stage of the derivation (see Marantz, 1993; Baker, 1997; Nakamura, 1997); it also takes into account the observation that pronominal objects in many languages tend to undergo object shift. Notice that according to the Bare Phrase Structure theory of the MP, pronominal clitics of Category D are heads and phrases at the same time (see the discussion in Chomsky, 1995: 249). This means that an object marker like *-bi-* in (21b) first undergoes A-movement to SpecAsp as a DP and then incorporates into Pr as a D⁰ from this position.¹³

In the light of these remarks, consider now the examples in (22) from Greek (Anagnostopoulou, 2003: 194). The contrast between (22a) and (22b) is reminiscent of the contrast between (19a) and (19b). Theme passivisation is excluded in the Greek double object construction in (22a) in the presence of the full goal DP *tis Marias*, but becomes possible if the goal is realised as the pronominal clitic *tis* in (22b).

Anagnostopoulou (2003) explains the contrast in (22) as follows: she assumes that the goal in Greek double-object constructions is base-generated in a position from where it c-commands the theme. The goal in (22a) is therefore closer to SpecT than the theme, and movement of the theme to SpecT thus violates the MLC; this part of her analysis is similar to the account we have provided for the ungrammaticality of (19a), the main difference being that we assume that the goal (= applied object) in applicatives is not base-generated in a higher position but c-commands the theme as a result of movement. Furthermore, Anagnostopoulou argues that clitics in Greek raise to T where they attach to the verb. Importantly, the goal in the grammatical (22b) is a clitic, which means that it has moved from its base position to T. As a result, theme movement to SpecT no longer violates the MLC in (22b): the clitic and the feature which attracts the theme are now in the minimal domain of the same head (i.e. T), and the traces/copies of moved elements generally do not induce MLC-violations. Therefore, neither the clitic in T nor its trace block movement of the theme to SpecT.

This idea can now be applied to the Kinyarwanda example in (19b). Since the applied object DP needs to check and delete its case feature before incorporation, the case feature of the theme is not deleted after checking (Burzio's generalisation) and remains active. When the applied object undergoes head movement to Pr and moves with the verb to T, it ends up in the minimal domain of the same head whose feature also attracts the theme to move to SpecT. Furthermore, the applied object-clitic does not c-command the theme DP from its position adjoined to Pr⁰ and is therefore not closer to the targetted TP than the theme after incorporation (see the discussion of (12) above). Consequently, neither the clitic itself nor its trace/copy block movement of the theme DP from the lower specifier to SpecT. Therefore, the theme DP can move and check its case feature and T's ϕ - and EPP-features, and (19b) is well-formed. The tree diagram in (23) illustrates this derivation.

We now turn to (19c), where extraction of the applied object licences passivisation of the theme. Again, the basic structure looks as in (20), where the MLC would only allow for the applied object to move to SpecT. However, if the applied object is extracted, the theme can be passivised.

At first sight, it seems as if passivisation of

Example 24

-
- (24a) *Amaazi y-a-menn-w-e-ho umwaana
 water SP-PST-pour-PASS-ASP-APPL child
 'The water was poured on the child'
- (24b) umwaana wo amaazi y-a-menn-w-e-ho
 child REL water SP-PST-pour-PASS-ASP-APPL
 'the child on whom the water was poured'
-

the theme in (19c) follows from the fact that relative operators in Kinyarwanda are phonetically unrealised. If phrases without phonological content are generally invisible for the MLC, then the theme can be moved to SpecT across the applied object in (19c) simply because the latter is an empty operator. At a later stage, this operator is raised to SpecC, leaving behind a phonetically unrealised copy, but the possibility of moving the theme to SpecT does not rely on this movement step, since the empty operator was already phonetically null before movement.

However, notice that there are dialects of Kinyarwanda which employ an overtly realised relative operator. As (24) shows, the relevant dialects of Kinyarwanda exhibit the same contrast that was also attested in (19). Theme passivisation is excluded if the applied object is in SpecAsp, but becomes possible once the applied object has been extracted — (24b). Since the applied object in (24b) is phonetically realised as *wo*, the explanation for the contrast in (24) has to rely on the same idea that explained theme passivisation in (19b), where the applied object is incorporated into the verb: (24b) is grammatical, because the applied object has moved to SpecC, and its trace (now phonetically ‘invisible’) no longer blocks extraction of the theme.

However, this analysis presents a problem with cyclicity. In the MP, syntactic structures are built strictly bottom-to-top, in a successive application of Merge and Move. Substitution operations, which create specifiers and complement positions, obey the extension condition — see (17) above. But if theme movement is made possible by moving the applied object out of the way in (19c), then one would have to assume that movement of the applied object to SpecC takes place *before* movement of the theme to SpecT. In this case, however, the latter movement operation would be countercyclic — merging the theme into SpecT when CP has already been formed violates the extension condition, since the newly-formed phrase marker K^* does not include the initial phrase marker K as a proper part.

The problem that the effects of the MLC with respect to A-movement to SpecT can sometimes be undone by moving an intervening phrase to SpecC has been addressed in various places in the literature. In the following

paragraph, we briefly discuss the solutions proposed in McGinnis (2001; 2004), Legate (2002) and Anagnostopoulou (2003).

The proposals offered in McGinnis (2001; 2004) and Anagnostopoulou (2003) are built on Chomsky’s (1999; 2000) theory of phases. In the MP, it is assumed that the complete set of lexical elements used in the derivation (the lexical array) is selected from the lexicon at the outset of the derivation. However, according to Chomsky, the computational system does not have constant access to the lexical array throughout the derivation. Rather, Chomsky argues that the derivation proceeds in cycles, or ‘phases’. During each phase, only a subset of the lexical array is available for the computation. No element of the lexical array which is not part of this subset can be accessed by the computational system until the respective phase is completed. Once the phase is completed, it is sent off to the interface components and the computation proceeds; the computational system now has access to the lexical sub-array which determines the next phase. Crucially, according to Chomsky, TP is not a phase, but CP is.

In order to solve the problem with cyclicity that arises when movement to SpecC obviates MLC violations, McGinnis (2001) adopts a proposal articulated in Chomsky (1999; 2000), according to which the MLC is only evaluated at the level of a phase (see also McGinnis, 2004). According to this idea, the derivation of (19c) would proceed in a strictly cyclic fashion. The theme would move to SpecT before the applied object moves to SpecC. Crucially, the legitimacy of this operation with respect to the MLC is not checked immediately once the movement step actually occurs, but only once the next phase (i.e. CP) has been completed. At that stage, however, the applied object has been moved as well, and the computational system recognises that the only DP intervening between the trace of the theme in the lower SpecAsp and SpecT is the copy of the applied object, which is now in SpecC. Since this copy has no phonological material in either (19c) or (24b), the derivation converges.

An alternative is proposed in Anagnostopoulou (2003). In contrast to McGinnis, Anagnostopoulou assumes that every movement step is strictly constrained by the MLC, which cannot be circumvented by moving

intervening material out of the way at some later stage. Instead, Anagnostopoulou assumes that the cyclicity requirement is relaxed as far as derivations within a phase are concerned. She argues that movement to SpecT can in fact take place *after* CP has already been projected, since T and C are part of the same phase. With respect to (19c), this would mean that the applied object moves to SpecC first. The theme can then target TP and move to SpecT, an operation which violates the extension condition, but which obeys the MLC.

A third solution is proposed in Legate (2002), who argues that operator phrases move to an unspecified A-bar position between TP and VP before they move to SpecC. Furthermore, she suggests that when T attracts a phrase to check its ϕ - and EPP-features, it ignores elements in A-bar positions. Applying this idea to (19c), we would have to assume that the relative operator (= applied object) in the higher SpecAsp first moves to an A-bar position between T and Asp. When T attracts the theme, the operator in this A-bar position is invisible for the MLC, and the theme can move to SpecT without violating the MLC or the extension condition. In a third step, the applied object moves to SpecC.

In principle, all these analyses explain the grammaticality of the example in (19c). However, each analysis comes at a cost. We have to assume a semi-representational interpretation of the MLC (= McGinnis proposal) or give up the idea that substitution operations are always strictly cyclic (= Anagnostopoulou's

approach). Legate's theory avoids these shortcomings, but introduces an otherwise unmotivated additional movement operation associated with operators and furthermore stipulates that A-movement across a phrase in an A-bar position does not violate the MLC.¹⁴

Interestingly, there is yet another configuration in which a relative operator corresponding to the applied object would not block passivisation of the theme. Recall that, according to the definition of closeness in (10), an element β only blocks movement of an element α if β c-commands α . This means that the absence of intervention effects in (19c) could also be explained if it could be shown that the relative operator *does not c-command* the theme. This is exactly the solution we suggest to explain the obviation effects of relativisation in Kinyarwanda observed in (19c) and (24b). Below, we argue on independent grounds that in Kinyarwanda, a relative operator is represented as the (NP- or DP-) complement of a null determiner head D, and that it is the maximal projection of this null D-head which occupies SpecAsp in an object relative construction. As a consequence, the relative operator in examples such as (19c) and (24b) does not c-command the theme and therefore does not block movement of the theme to SpecT. This of course raises the question of why the complex DP in SpecAsp which contains the null determiner and the relative operator does not create an MLC effect. Postponing the answer to this question and the discussion of the details of this analysis, for the

Examples 25–26

-
- (25a) *Umubooyi y-a-ya-menn-ye-ho umwaana
 cook SP-PST-OM-pour-ASP-APPL child
 'The cook poured it on the child'
- (25b) Umubooyi y-a-ya-mu-menn-ye-ho
 cook SP-PST-OM-OM-pour-ASP-APPL
 'The cook poured it on him/her'
- (25c) Umwaana y-a-ya-menn-w-e-ho n'umubooyi
 child SP-PST-OM-pour-PASS-ASP-APPL by cook
 Lit.: 'The child was it poured on by the cook'
- (25d) umwaana umubooyi y-a-ya-menn-ye-ho
 child cook SP-PST-OM-pour-ASP-APPL
 'the child on whom the cook poured it'
-
- (26) [_{PrP} subj [_{OM_i}+OM_j]+verb [_{AspP} t_i [t_i [Asp VP]]]]]
-

moment we only note here that this proposal offers an alternative way to explain the example in (19c) without having to rely on a semi-representational version of the MLC, countercyclic derivations or otherwise unmotivated operator movement to an intermediate A-bar-position.

Object marking of the theme

As was shown in (4b) and (7), repeated as (25), the theme can only undergo pronoun incorporation in Kinyarwanda locatives once the applied object has been extracted, passivised or incorporated into the verb; see (25a–25d).

In order to explain the ungrammatical (25a), we can rely on the structure in (20) again. Pr attracts the closest possible gender feature of a DP in SpecAsp. Obviously, both the applied object and the theme carry such a feature, and both DPs have checked their structural case feature in SpecAsp. Therefore, both D-heads in principle could be attracted by Pr. However, since the applied object c-commands the theme, the MLC explains that incorporation of the theme is impossible.¹⁵

Theme incorporation is possible, however, when the applied object is also an incorporated pronoun, as in (25b). In this case, Pr carries two gender features. First, the applied object undergoes head movement and adjoins to Pr. As a result, it is now part of Pr's minimal domain and no longer c-commands the theme, while its copy is not phonetically 'visible'. Therefore, the theme can now incorporate into Pr in a second step, since this movement step is no longer blocked by the MLC. This derivation is illustrated in (26).

Movement of the applied object to SpecT in a passive construction, as in (25c), has the same effect on incorporation of the theme. We

assume that the applied object moves first and creates SpecT. Since this move leaves a phonetically-unrealised copy in the higher SpecAsp, the theme is now allowed to move as well without violating the MLC; it adjoins to Pr and incorporates into the verb.

One might object that the proposed derivation raises a problem with cyclicity again. Recall from the discussion above that in the MP, the effects of cyclicity are derived from the extension condition in (17), and this condition is clearly violated if the theme adjoins to Pr only after SpecT has already been created. However, it is important to note that head adjunction *never* obeys the extension condition, which generally only holds for (overt) substitution (see Chomsky, 1995: 327). This follows from the very nature of head movement. When substitution merges a phrase XP with an existing phrase marker K, the extension condition requires that α be added to the root of the phrase marker, such that K* can include K as a proper part, as in (27a). But head movement can never target the root of a phrase marker, because a head X⁰ can only adjoin to another head Y⁰, and the root of a phrase marker K is always non-minimal (at least in movement constructions), as in (27b).

The exceptional behaviour of head adjunction (and adjunction in general) has been addressed in a number of studies (see Kitahara, 1995; Bobaljik & Brown, 1997; Chomsky, 2000). We are not going to discuss these proposals here. It is sufficient for our purposes to emphasise the fact that the extension condition does not hold for head adjunction and that, therefore, movement of the theme to Pr after the applied object has moved to SpecT does not pose a problem for our approach.

Finally, the same considerations explain the

(27) a. Substitution

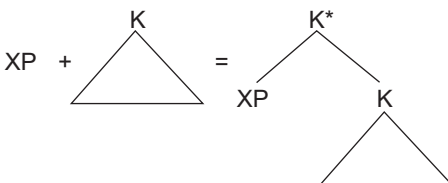

b. Head adjunction

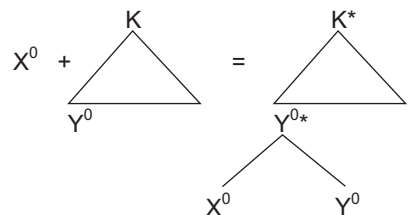

the move-ment of the theme to SpecC but rather a different movement process that is directly linked to relativisation, then it might be possible to explain (28a) in terms of the MLC as well.

This is in fact the approach that we take in this paper. For our account of (28a), we adopt a proposal about the syntax of relative clause constructions put forward by Boeckx (2003), which is based on the analysis presented in Kayne (1994). Kayne argues that the head noun of a relative clause construction is generated inside the relative clause and moves to SpecC (the head noun therefore *is* the relative operator). Kayne implements this idea by assuming that a relative clause is realised as the CP complement of the head of the complex DP which contains the relative clause. The derivation of the relative clause construction *the car that I bought* is informally illustrated in (29) — notice that (29a) does not represent the fact that the determiner is only merged with the CP after the relative operator has moved, in accordance with the extension condition.

On the basis of Kayne's proposal, Boeckx (2003) argues that the relative operator/head noun is actually the (NP- or DP-) complement of a determiner which is stranded inside the relative clause when the operator moves to SpecC. This stranded determiner is phonetically null in English; see (30).

Since Postal (1969), it is a widely-accepted assumption that determiners and pronouns are

elements of the same category; they are represented as D-heads in the MP. A pronoun can therefore be regarded as a determiner without an overt complement. Since the complement of the determiner in (30b) is a trace (i.e. the phonetically unrealised copy of the relative operator), Boeckx (2003) assumes that the stranded D-element acts as some sort of (resumptive) pronoun.

This latter point becomes crucial when Boeckx's proposal is applied to relative clauses in Kinyarwanda. We suggest that the structure of relative constructions in Kinyarwanda resembles that of the English relative clause in (30). A relative operator is an NP-complement of a null determiner; when the operator moves to SpecC, the determiner is left behind inside the relative clause.¹⁶ As in English, the stranded D-head in Kinyarwanda is pronominal; importantly, however, as was shown above, pronouns in Kinyarwanda are clitics which incorporate into the verb as object markers. This means that the D-head which selects the relative operator/head noun in a Kinyarwanda relative clause must also incorporate as a (phonetically unrealised) object marker; otherwise, no relative clause can be formed. We therefore assume that the formation of a relative clause construction such as (31) proceeds in the manner illustrated in (32).

(32a) represents the stage of the derivation where the relativised object DP containing the

Examples 31–33

(31) umukoobwa umuhuungu y-a-haa-ye igitabo
 girl boy SP-PST-give-ASP book
 'the girl to whom the boy gave the book' (Kimenyi, 1980: 62)

(32a) [_{PrP} haaye [_{ASP} [_{DP} D [_{NP} umukoobwa]], [_{VP} t_i]]]

(32b) [_{PrP} D-haaye [[_{DP} t [_{NP} umukoobwa]], [_{VP} t_i]]]

(32c) [_{DP} D [_{CP} [_{NP} umukoobwa] [_{TP} umuhuungu [ya-D-haaye [[_{DP} t_i] [_{VP} t_i]]]]]]

(33a) incwadi isitshudeni esi-yi-fund-a-yo
 letter student RC-OM-read-FV-RS
 'the letter that the student is reading'

(33b) ukudla ugoro a-ku-phek-a-yo
 food granny RC-OM-cook-FV-RS
 'the food that granny cooks'

null determiner and the head noun-NP *umukoobwa*, ‘girl’ (which functions as the relative operator), has moved out of the VP to SpecAsp. Furthermore, AspP has merged with Pr, and the verb has moved to Pr. In (32b), the head of the relativised DP incorporates into the verb (by adjoining to Pr). Finally, once TP is projected and C is merged with TP, the complement of the incorporated D moves to SpecC.

We hence assume that in Bantu languages, which realise pronouns as clitics, incorporation of the head of a relativised DP is generally required and always goes hand-in-hand with the extraction of the relative operator. Overt evidence for the assumption that relativisation in Bantu involves incorporation of a pronominal D-head is provided by Southern Bantu languages such as Zulu (Nguni). Like (standard) Kinyarwanda, Zulu does not employ overt relative pronouns in relative clauses (instead, the verb is marked with a special subject prefix called the ‘relative concord’: see Poulos (1982) and Zeller (2004) for details). Importantly, (33) shows that object relative clauses in Zulu, as in many other Southern Bantu languages, require the presence of an incorporated object pronoun that agrees with the head noun. The object clitic is obligatory; without it, the constructions in (33) are ungrammatical. This fact follows from the analysis outlined above, according to which the pronouns in (33) are D-heads that select the relative operators as their complements. Whereas these D-heads are phonetically null in English and Kinyarwanda,

they are realised as overt object markers in languages such as Zulu.

Obviously, the incorporation of the head of a relativised DP is subject to the same locality constraints that also govern the incorporation of overt object pronouns in Kinyarwanda. What we are suggesting, therefore, is that the type of movement that violates the MLC in examples such as (28a) is not A-bar movement but head movement. The gender feature of Pr attracts the closest D-head of an object in SpecAsp. Since the applied object in (28a) is located in the higher specifier position, it is closer to the target Pr than the head of the DP corresponding to the theme. The MLC therefore blocks incorporation of the head of the theme, and since the extraction of the relative operator is contingent on this movement step, relative clause constructions such as (28a) are ruled out.

The tree diagram in (34) illustrates this situation. Incorporation of the head of the theme DP is blocked by the intervening applied object. Therefore, extraction of the complement of this head (the relative operator/head noun) is also impossible.

On the basis of the structure in (34), the grammaticality of (28b) and (28c) now follows from the explanation that was provided for the data in (25b) and (25c): if the applied object has moved to SpecT or adjoined to Pr, then the head of the theme DP can incorporate into the verb, and theme relativisation is possible.

A further advantage of our proposal is that it solves the problem with cyclicity that was discussed above. If a relative operator is represented as the complement of a D-head which must move and adjoin to Pr, then it follows that the theme can undergo movement (to SpecT or Pr) from the lower SpecAsp when the applied object is relativised. On the one hand, the relative operator itself is realised as a complement inside the relativised object DP in the higher SpecAsp. As such, it does not c-command the theme and therefore does not count as closer to the target node TP or Pr. On the other hand, the head of the applied object DP in the higher SpecAsp, which could potentially create an MLC-configuration, adjoins to Pr in order to allow extraction of its complement. Therefore, it does not block theme movement either, since an incorporated D-head no longer counts as a barrier in terms of the MLC. Our analysis hence assumes that

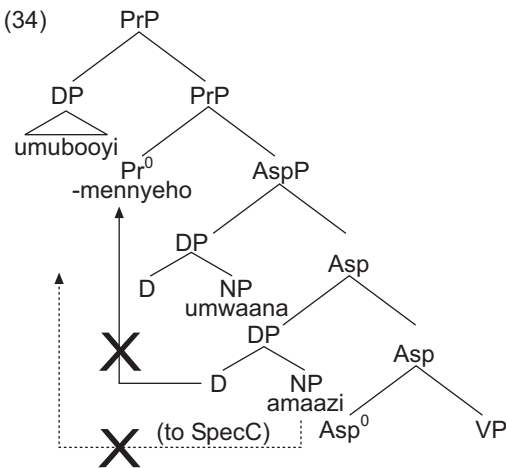

(19c) is grammatical for the same reason as (19b) is, and (25d) is licensed by the same configuration as (25b). We do not have to relax the extension condition or rely on a semi-representational version of the MLC in order to explain the grammaticality of theme passivisation or incorporation in locative applicative constructions in which the applied object is relativised. The relevant data follow directly from the proposal illustrated in (32) and (34), which gains independent support from our analysis of the data in (28).

Other types of applicatives in Kinyarwanda

In this section, we address applicative constructions in Kinyarwanda in which the theme and the applied object do not show the asymmetrical behaviour attested with objects in locative applicatives. The examples in (35)

to (38) are based on instrumental applicatives, but similar examples can be constructed for other types of applicatives as well.¹⁷ The following differences between instrumental and locative applicatives are noteworthy:

- (i) word order: in contrast to locative applicatives — see (18) — the word order in Kinyarwanda instrumental applicatives is flexible. The theme can precede the applied object and *vice versa*; see (35)
- (ii) object marking: with instrumental applicatives, it is possible to realise either of the two objects as an incorporated pronoun; see (36)
- (iii) passivisation: an instrumental applicative allows for passivisation of both the instrument/applied object and the theme argument; see (37)
- (iv) relativisation: instrumental applicatives allow for each of the two objects to be

Examples 35–38

-
- (35a) Umugabo y-a-tem-eesh-eje igiti umuhoro
man SP-PST-cut-APPL-ASP tree machete
'The man cut the tree with the machete'
- (35b) Umugabo y-a-tem-eesh-eje umuhoro igiti
man SP-PST-cut-APPL-ASP machete tree
'The man cut the tree with the machete'
- (36a) Abanyarwaanda ba-nyw-eesh-a inzoga umuheha
Rwandans SP-drink-APPL-FV beer straw
'Rwandans drink beer with a straw'
- (36b) Abanyarwaanda ba-wu-nyw-eesh-a inzoga
Rwandans SP-OM-drink-APPL-FV beer
'Rwandans drink beer with it'
- (36c) Abanyarwaanda ba-yi-nyw-eesh-a umuheha
Rwandans SP-OM-drink-APPL-FV straw
'Rwandans drink it with a straw'
- (37a) Umuhoro w-a-tem-eesh-ej-w-e igiti
machete SP-PST-cut-APPL-ASP-PASS-ASP tree
Lit.: 'The machete was cut the tree with'
- (37b) Igitu cy-aa-tem-eesh-ej-w-e umuhoro
tree SP-PST-cut-APPL-ASP-PASS-ASP machete
'The tree was cut with the machete'
- (38a) umuhoro umugabo y-a-tem-eesh-eje igiti
machete man SP-PST-cut-APPL-ASP tree
'the machete with which the man cut the tree'
- (38b) igiti umugabo y-a-tem-eesh-eje umuhoro
tree man SP-PST-cut-APPL-ASP machete
'The tree the man cut with the machete'
-

extracted in a relative clause: see (38)

In order to explain the difference between locative and instrumental applicatives, we follow Baker (1988; 1992) and Nakamura (1997) and assume that the latter type of applicative is not derived syntactically by incorporation, but that the instrumental applicative morpheme combines with the verb in the lexicon and adds a new argument to the argument structure of the verb. Both the theme and applied object in instrumentals are therefore directly theta-marked by the verb. This means that, in contrast to locatives, the applied object of an instrumental applicative is not merged into the tree as the complement of an affixal preposition but as the complement of the verb. The theme argument is located in SpecVP; see (39).

Evidence for the claim that locative and instrumental-type applicatives in Kinyarwanda are derived by different processes is provided by the different morphological realisations of the applicative morphemes. Whereas the instrumental applicative morpheme *-eesh-* and its allomorphs are verbal affixes which precede morphemes such as the aspect marker *-(y)e-* and the passive morpheme *-w-*, the locative applicative suffix *-ho* and its allomorphs are suffixes which always follow the last morpheme of the verb.

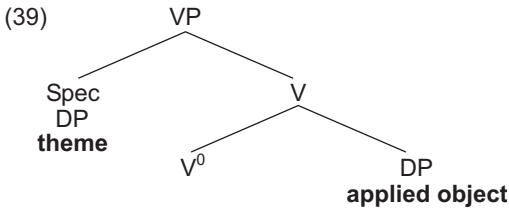

Example 40

- (40a) Abanyarwaanda ba-ra-wu-yi-nyw-eesh-a
 Rwandans SP-FOC-OM-OM-drink-APPL-FV
 'Rwandans drink it with it'
- (40b) Inzoga y-a-wu-nyw-eesh-ej-w-e n'abanyarwaanda
 beer SP-PST-OM-drink-APPL-ASP-PASS-ASP by Rwandans
 'Beer was drunk with it by the Rwandans'
- (40c) Umuheha w-a-yi-nyw-eesh-ej-w-e n'aban yarwaanda
 straw SP-PST-OM-drink-APPL-ASP-PASS-ASP by Rwandans
 Lit.: 'The straw was it drunk with by the Rwandans'

Importantly, the syntactic representation of the applied object has implications for its case properties. As argued in Baker (1988; 1992) and Nakamura (1997), whereas the applied object of a locative cannot receive inherent case (since it is the complement of an incorporated preposition), this option is available in other types of applicatives, where the applied object is the sister of the verb. This means that in instrumental applicatives, the applied object may remain inside the VP and receive inherent case, while only the theme moves to SpecAsp in order to check its structural case feature. As a consequence, we derive the word order theme > applied object exhibited in (35a). This word order is not attested in locatives, since here the applied object cannot get inherent case. Both object DPs have to move to SpecAsp in locatives; the MLC determines that the theme always occupies the lower specifier, and the word order applied object > theme is hence the only one attested.

However, although the applied object can remain in the VP in instrumental applicatives, a derivation involving multiple specifiers is also possible with this type of applicative. Since Asp in Kinyarwanda can optionally attract two DPs with structural case features, there is no reason why this option should only be available in locatives. We assume that the applied object in instrumentals and similar types of applicatives may also be equipped with a structural case feature, in which event both the theme and the applied object have to move to SpecAsp. The derivation then proceeds exactly like the derivation of locative applicatives. Due to the MLC, the theme has to move to SpecAsp first, and the applied object moves to a higher specifier, deriving the word order applied object > theme in (35b).

Our claim that both objects of an instrumental applicative may be marked with structural

case predicts that both objects may exhibit primary object properties simultaneously. This prediction is indeed borne out, as shown in (40). (40a) shows that the theme and the applied object can incorporate into the verb together; (40b) and (40c) illustrate that passivisation of one object is compatible with incorporation of the other. As was argued above, both incorporation and passivisation require the relevant DP to move to SpecAsp before A- or head movement takes place. (40) therefore provides evidence that Asp in instrumental applicatives can also project multiple specifiers.

Our proposal explains why both the theme and the applied object can be extracted, passivised and object-marked in instrumental applicatives. If both objects move to SpecAsp, the resulting configuration (in which the applied object c-commands the theme) resembles that of locative applicatives and hence allows for the applied object to undergo movement. However, if the applied object remains inside the VP and receives inherent case, then the theme is the only DP in SpecAsp. In this case, a feature which needs to be checked by the D-feature of a DP will always attract the theme first, since the theme is now closer to the attractor than the applied object. This means that in the grammatical examples in (36c), (37b) and (38b), the applied object is inside the VP, and therefore does not block movement of the theme. In contrast, in the corresponding ungrammatical examples from locative applicatives, the applied object is in SpecAsp and hence intervenes between (the trace of) the theme and its landing site.

The absence of MLC-effects induced by the applied object in instrumental applicatives is

therefore a consequence of the fact that the applied object can receive inherent case inside the VP. Our proposal thus correlates the symmetrical behaviour of objects in certain types of applicatives in Kinyarwanda with the more liberal word order of these constructions. The differences between symmetrical and asymmetrical (locative) applicatives in Kinyarwanda basically follow from one single syntactic difference: only the applied object of a locative is the argument of a preposition that incorporates into the verb.

Conclusion

According to the analysis we presented in this paper, the major syntactic properties of locative applicatives concerning word order and object asymmetries, and the respective differences between locatives and other types of applicatives, are the result of feature-driven movement operations constrained by the MLC. In the light of this analysis, the empirical properties of Kinyarwanda applicatives can be regarded as strong evidence for some of the core mechanisms and principles postulated in the MP, such as the system of feature attraction and feature checking, the MLC, the theory of multiple specifiers, the extension condition on substitution, and Bare Phrase Structure Theory.

Nevertheless, we have departed from standard minimalist assumptions with respect to the phrasal architecture of the sentence, which we have used as the basis for our proposal. We have adopted the view of sentence structure advocated in Nakamura (1997), who postulates two functional categories between the TP and the VP, namely PrP and AspP. While Pr introduces the external argument in

Examples 41–42

-
- (41a) *Cha:kujā sh-pik-il-ila wa:na na Hamadi
 food SP-cook-APPL-PASS children by Hamadi
 'Food was cooked for the children by Hamadi'
- (41b) *Hamadi Ø-sh-pik-il-ile wa:na cha:kujā
 Hamadi SP-OM-cook-APPL-PAST children food
 'Hamadi cooked it for the children, the food' (Nakamura, 1997: 269)
- (42) nama ya Nu:ru Ø-m-tilang-il-ilo: mwa:na
 meat REL Nuru SP-OM-cut-APPL-PAST child
 'the meat that Nuru cut for him, the child' (Nakamura, 1997: 270)
-

SpecPr, Asp establishes agreement with an object DP in SpecAsp and checks the DP's structural case feature. However, the phrase structure representation typically assumed in the MP is slightly different from the one employed by Nakamura. According to Chomsky (1995; 1999; 2000), there is only one functional projection that intervenes between TP and VP, the light verb phrase *vP*. The external argument is introduced in Spec_v, and the head of *vP* is responsible for object agreement and case checking. It would be worthwhile to test whether our analysis can be adjusted to this minimalist view of phrase structure. In Zeller (2005), a proposal along these lines is made, which is based on the idea that both the theme and the applied object occupy multiple specifier positions of the verb (with the applied object moving to a higher SpecV on top of the theme in the lower SpecV). The success of such a proposal would further corroborate the minimalist approach to the study of Bantu syntax that we advocate here.

The crosslinguistic analyses of applicatives provided by e.g. Bresnan and Moshi (1990) or Nakamura (1997) suggest that there is a great degree of variation among Bantu languages with respect to the properties of objects in applicative constructions. This variation may provide an empirical test case for our analysis, in which we have focussed exclusively on the properties of applicatives in Kinyarwanda. Consider, for example, benefactive applicatives in Chimwiini, which are discussed in Nakamura (1997). Nakamura notes that Chimwiini benefactives pattern with Kinyarwanda locatives, in that the theme can be neither passivised nor realised as an object marker; see (41). However, Chimwiini benefactives seem to differ from Kinyarwanda locatives, in that the theme can be extracted in a relative clause such as (42).

At first sight, Chimwiini seems to pose a problem for the analysis we presented in the preceding sections. Since theme passivisation and incorporation are banned in (41), our theory predicts that theme extraction across an applied object is ungrammatical as well.

However, on closer inspection, (42) confirms rather than contradicts our analysis. Notice that (42) is an instance of clitic right-dislocation, a construction in which an extraposed DP is linked to a pronominal clitic inside the associ-

ated clause (see Bresnan & Mchombo, 1987 for Chichewa). Therefore, the verb in (42) bears the object marker *-m-*, which is linked to the extraposed DP *mwa:na* — which we assume is base-generated in the right periphery of the clause in (42). Since the right-dislocated topic is interpreted as the beneficiary, the corresponding object clitic *-m-* is the applied object, which means that it has adjoined to Pr and incorporated into the verb from the position in the higher SpecAsp. According to our analysis, this in turn implies that the head of the lower theme DP is also free to undergo head movement and that, therefore, its complement (the relative operator) can be extracted from the DP in the lower SpecAsp. (42) is therefore grammatical for the same reason as (28b).

As far as we can tell from the data provided by Nakamura, Chimwiini benefactive applicatives are thus not that different from locative applicatives in Kinyarwanda. The examination of further data from Chimwiini as well as from related languages will help establish whether the analysis developed in this paper can explain applicative constructions in Bantu more generally.

Notes

- ¹ Morphemes are glossed as follows: APPL = applicative; ASP = aspect; FOC = focus marker; FV = final vowel; OC = object clitic; OM = object marker; PASS = passive; PRES = present tense; PST = past tense; RC = relative concord; REL = relative marker; RS = relative suffix; SP = subject prefix. Where possible, we have adjusted the glosses of examples that we adopted from the literature to our system. The examples have not been marked for tone, since pronunciation is irrelevant for our analysis.
- ² Bresnan and Moshi (1990) and Moshi (1998) distinguish between symmetrical languages, in which both objects of a ditransitive applicative show primary object properties, and asymmetrical languages, in which only one object has these properties. Most applicatives in Kinyarwanda fall into the former category — see below for a discussion of instrumental applicatives; for a detailed description, see Kimenyi (1980) and Ngoboka (2005) — but locative applicatives in Kinyarwanda are clearly asymmetrical. This shows that the symmetrical/asymmetrical distinction can also

be drawn between different types of applicatives within the same language.

- ³ Nakamura (1997) explains examples such as (5b) on the basis of a transderivational formulation of the Minimal Link Condition, according to which a derivation is excluded if an alternative derivation based on the same numeration but with shorter movement steps also exists. Applicatives such as (2) are contrasted with non-applied constructions such as (i) below, which allow theme extraction. According to Nakamura's analysis, the theme in (i) is closer to SpecC than in (2); movement of the theme to SpecC is hence shorter in (i), and (5b) is therefore ruled out.
- ⁴ One might argue that the contrasts in (6) to (8) can be explained by case theory if it is assumed that structural case assignment in Kinyarwanda requires *linear adjacency* of the verb and the object (cf Stowell, 1981). Notice that in Kinyarwanda locatives, the applied object obligatorily precedes the theme; therefore, the theme would not be adjacent to the verb and hence could not get structural case unless the applied object has been subject to an operation which creates adjacency of the theme and the verb. However, there are a number of problems with this approach. First, structural case assignment is possible in Kinyarwanda even if an adverb intervenes between the verb and the object, as shown in (ii) and (iii) below. Second, the case-adjacency approach cannot explain the impossibility of theme extraction in (5b), since extraction is not contingent on structural case. Third, it is not clear how the grammatical example in (7a) would be derived, where both

objects are marked on the verb and hence must both have structural case (but only one object can be adjacent to the verb). Fourth, as we show below in the text, there are applicatives in Kinyarwanda which, in contrast to locatives, do allow passivisation of the theme with a full applied object DP adjacent to the verb. And fifth, any account which explains syntactic phenomena on purely syntactic grounds should be preferable from a conceptual point of view to an explanation which needs to refer to phonological properties like adjacency.

- ⁵ In Chomsky (2000), the features of the target which trigger movement are called the Probe, the matching features are called the Goal, and feature-deletion under match is called Agree.
- ⁶ Notice that the *minimal* domain of a head X^0 includes the node representing its complement, but not the elements which are dominated by this node. In (12), YP is part of X^0 's minimal domain, but α is not (therefore, α can be attracted by XP). In this respect, the concept of a minimal domain differs from the notion of *domain* of X^0 , which is defined in Chomsky (2000) as including all nodes which are c-commanded by X^0 .
- ⁷ The idea expressed by this addendum also appears as part of an alternative definition of 'closeness' in Chomsky (1995: 356), which is given in (iv). Whereas our proposal essentially captures the spirit of Part (a) of (iv), we reject Part (b), which strikes us as contradicting the very idea of the MLC. For example, according to (b), a category in a specifier of a head X^0 does not count as closer to an attracting Category K than the complement of X^0 , since the

(i) Umubooyi y-a-menn-ye amaazi ku mwaana
 cook SP-PST-pour-ASP water on child
 'The cook poured water on the child'

(ii) ?Yohaani a-som-a keenshi Mariya
 John SP-kiss-FV often Mary
 'John often (many times) kisses Mary'

(iii) Mariya a-som-w-a keenshi na John
 Mary SP-kiss-PASS-FV often by John
 'Mary is often kissed by John'

(iv) If β c-commands α and τ is the target of raising, β is closer to K than α unless β is in the same minimal domain as (a) τ or (b) α .

specifier of X^0 and its complement form part of the same minimal domain. We find this consequence counter-intuitive. Our proposal is an attempt to implement the MLC in such a way that intervention effects can be captured strictly in terms of *c*-command. We therefore do not adopt (iv) for our analysis.

- ⁸ The fact that the EPP feature of Asp is always checked in the higher specifier may be because features of functional categories are hierarchically ordered and therefore determine the order in which checking takes place (Sabel, 2002).
- ⁹ McGinnis' proposal is based on Pylkkänen (2000), who argues that semantically different types of applicatives are represented structurally in different ways in the syntax. Pylkkänen distinguishes between 'high' applicatives, which denote a relation between an individual and an event, and 'low' applicatives, which relate two individuals to each other.
- ¹⁰ The implications of the extension condition for head adjunction are discussed below.
- ¹¹ Richards (1997) argues that in multiple wh-fronting languages such as Bulgarian, wh-phrases undergo movement to multiple SpecC-positions, and he claims that the second wh-phrase moves to a specifier position *below* the first, a process which he labels 'tucking in'. However, McGinnis (1998) suggests that tucking in processes only occur when two phrases check the same type of feature of a functional head (for example, all wh-phrases in Bulgarian check a [Q]-feature of C). In contrast, when movement to multiple specifiers is triggered by different features of a head, tucking in is impossible, and (17) must be obeyed. Importantly, although movement of both DPs to SpecAsp in (16) is triggered by ϕ -features, only the second movement operation also checks the EPP-feature of Asp. Therefore, the second DP (the applied object) cannot tuck in below the theme, but must be merged in a higher specifier, in accordance with (17). It therefore follows from McGinnis' proposal that our analysis in (16) can be maintained even if

tucking in processes are indeed possible in other constructions involving multiple specifiers.

- ¹² Our analysis implies that the subject DP of a passive always moves to SpecT past SpecAsp. This explains why languages such as French and Italian show agreement between the verbal past participle in Asp⁰ and the subject of a passive. In (v), the DP *les chaises* has moved to SpecAsp, triggering gender and number agreement with the participle. However, the structural case feature of the DP remains undeleted in the passive. The DP can therefore move on to the subject position to check (nominative) case in SpecT; see Chomsky (2000: 124) for further discussion.
- ¹³ Notice that our proposal requires a slight qualification of the idea that phrases with a checked (and hence deleted) structural case feature are frozen in place. Although this assumption continues to hold for phrasal movement, our proposal implies that head movement of a category with a deleted structural case feature is still possible. Therefore, although a pronominal object is inactive for XP-movement once its structural case feature has been checked, it can still undergo head movement and incorporate into the verb.
- ¹⁴ This latter aspect of Legate's proposal is motivated by the original Relativised Minimality approach (Rizzi, 1990) that underlies the MLC.
- ¹⁵ Notice that the *head* of the applied object in Example (25a) (= an empty D that combines with the NP *umwaana*) does not *c*-command the theme and is therefore *not* closer to the verb than the theme. However, incorporation of the theme is still banned, since a feature α attracted by K is always realised both on the head of a phrase and on the phrase itself. Therefore, the D-feature of the applied object is 'visible' at the level of the phrase and blocks incorporation in (25a). The assumption that features of a head percolate to the phrase level is necessary to explain other instances of the MLC as well, such as the wh-island effect discussed in (11) above; see (vi). The [Q]-feature of the wh-phrase *which car* which is

(v) Les chaises ont été repeintes par moi tout seul
the chairs have been repainted by me alone

(Belletti, 2001: 490)

(vi) *How do you wonder [_{CP} which car John could fix t t]?

located in the intermediate SpecC position is associated with the D-head of this phrase and therefore does not c-command the [Q]-feature of *how*. In order to explain that *which car* is closer to the matrix C than *how*, one has to assume that its [Q]-features are realised at the DP-level, such that the [Q]-feature of *which car* c-commands the [Q]-feature of *how*.

¹⁶ In those dialects of Kinyarwanda which employ relative pronouns — see (24b) — the complement of the null determiner is a DP which includes the relative pronoun and the head noun; see Kayne (1994) and Boeckx (2003) for details of the analysis of relative clause constructions involving relative pronouns.

¹⁷ For a detailed description of the properties of objects in these and other types of Kinyar-

wanda applicatives, see Kimenyi (1980; 1995) and Ngoboka (2005). Studies of applicative constructions in other Bantu languages include, among others, Bresnan and Moshi (1990) (for KiChaga and Chichewa); Harford (1993) (for Shona); Machobane (1993; 1997) (for Sotho); Ngonyani (1998) (for Swahili and Kindendeule); Moshi (1998) (for KiChaga); Alsina and Mchombo (1993) (for Chichewa); and the references cited in the text.

Acknowledgements — We thank Rosanne O'Hara, Dori Posel, Lisa Wiebesiek and Sabine Zerbian for helpful discussions, as well as two anonymous reviewers for their comments and suggestions.

References

- Alsina A & Mchombo SA.** 1993. Object asymmetries and the Chichewa applicative construction. In: Mchombo SA (ed) *Theoretical Aspects of Bantu Grammar*. Stanford: CSLI Publications, pp 11–44.
- Anagnostopoulou E.** 2003. *The Syntax of Ditransitives*. Berlin/New York: Mouton de Gruyter.
- Baker M.** 1988. *Incorporation: a Theory of Grammatical Function Changing*. Chicago: Chicago University Press.
- Baker M.** 1992. Thematic conditions on syntactic structures: evidence from locative applicatives. In: Roca IM (ed) *Thematic Structure: its Role in Grammar*. Berlin: Foris, pp 23–46.
- Baker M.** 1997. Thematic roles and syntactic structure. In: Haegeman L (ed) *Elements of Grammar*. Kluwer: Dordrecht, pp 73–137.
- Belletti A.** 2001. Agreement projections. In: Baltin M & Collins C (eds) *The Handbook of Contemporary Syntactic Theory*. Oxford: Blackwell Publishing, pp 483–510.
- Bobaljik JD & Brown S.** 1997. Inter-arboreal operations: head movement and the extension requirement. *Linguistic Inquiry* **28**: 345–356.
- Boeckx C.** 2003. *Islands and Chains*. Amsterdam: John Benjamins.
- Bowers J.** 1993. The syntax of predication. *Linguistic Inquiry* **20**: 219–251.
- Bresnan J & Mchombo SA.** 1987. Topic, pronoun and agreement in Chichewa. *Language* **63**: 741–782.
- Bresnan J & Moshi L.** 1990. Object asymmetries in comparative Bantu syntax. *Linguistic Inquiry* **21**(2): 147–181.
- Burzio L.** 1986. *Italian Syntax. A Government and Binding Approach*. Dordrecht/Boston/Lancaster/Tokyo: Reidel.
- Chomsky N.** 1995. *The Minimalist Program*. Cambridge/Massachusetts and London: MIT Press.
- Chomsky N.** 1999. Derivation by phase. MIT Occasional Papers in Linguistics 18.
- Chomsky N.** 2000. Minimalist inquiries: the framework. In: Martin R, Michaels D & Uriagereka J (eds) *Step by Step. Essays on Minimalist Syntax in Honor of Howard Lasnik*. Cambridge/Mass.: MIT Press, pp 89–155.
- Chomsky N.** 2001. Beyond Explanatory Adequacy. Manuscript, MIT.
- Harford C.** 1993. The applicative in Chishona and lexical mapping theory. In: Mchombo SA (ed) *Theoretical Aspects of Bantu Grammar*. Stanford: CSLI Publications, pp 93–110.
- Jaeggli O.** 1986. Passive. *Linguistic Inquiry* **17**: 587–622.
- Kayne R.** 1994. *The Anti-symmetry of Syntax*. Cambridge: MIT Press.
- Kimenyi A.** 1980. *A Relational Grammar of Kinyarwanda*. Berkeley: University of California Press.

- Kimenyi A.** 1995. Kinyarwanda applicatives revisited. Keynote address at the 8th Niger-Congo Syntax-semantics Workshop, Boston University. Available at <http://www.kimenyi.com/kinyarwanda-applicatives-revisited.php> [accessed 3 April 2006].
- Kitahara H.** 1995. Target A: deducing strict cyclicity from derivational economy. *Linguistic Inquiry* 26: 47–77.
- Larson R.** 1988. On the double object construction. *Linguistic Inquiry* 19: 335–391.
- Legate JA.** 2002. Phases in 'Beyond Explanatory Adequacy'. Manuscript, MIT, Cambridge.
- Machobane MM.** 1993. The ordering restrictions between Sesotho applicative and causative affixes. *South African Journal of African Languages* 13(4): 129–137.
- Machobane MM.** 1997. Sesotho control verbs with applicative suffix. *South African Journal of Linguistics* 15(2): 59–64.
- Marantz A.** 1993. Implications of asymmetries in double object constructions. In: Mchombo SA (ed) *Theoretical Aspects of Bantu Grammar*. Stanford: CSLI Publications, pp 113–148.
- McGinnis M.** 1998. *Locality in A-movement*. Doctoral dissertation, MIT, Cambridge.
- McGinnis M.** 2001. Variation in the phase structure of applicatives. In: Pica P & Rooryck J (eds) *Linguistic Variation Yearbook 1*. Amsterdam: John Benjamins, pp 101–142.
- McGinnis M.** 2004. Lethal ambiguity. *Linguistic Inquiry* 35: 47–95.
- Moshi L.** 1998. Word order in multiple object construction in Kivunjo-Chaga. *Journal of African Languages and Linguistics* 19: 137–152.
- Nakamura M.** 1997. Object extraction in Bantu applicatives: some implications for minimalism. *Linguistic Inquiry* 28(2): 252–278.
- Ngoboka JP.** 2005. *A Syntactic Analysis of Kinyarwanda Applicatives*. Unpublished MA thesis, University of KwaZulu-Natal, Durban, South Africa.
- Ngonyani D.** 1998. Properties of applied objects in Kiswahili and Kidendeule. *Studies in African Linguistics* 27(1): 67–93.
- Postal PM.** 1969. On so-called 'pronouns' in English. In: Reibel DA & Schane SA (eds) *Modern Studies in English*. Englewood Cliffs: Prentice-Hall Inc., pp 201–224.
- Poulos G.** 1982. *Issues in Zulu Relativization*. PhD thesis, Department of African Languages, Rhodes University, Grahamstown, South Africa. *Communication* No. 11.
- Pykkänen L.** 2000. What applicative heads apply to. Proceedings of the 24th Annual Penn Linguistics Colloquium. UPenn Working Papers in Linguistics, Vol. 6(4). Available at <http://www.lot.let.uu.nl/zs2001/papers-marantz/applicatives.doc> [accessed 3 April 2006].
- Richards N.** 1997. *What Moves Where When in Which Language?* Doctoral dissertation, MIT, Cambridge.
- Rizzi L.** 1990. *Relativized Minimality*. Cambridge: MIT Press.
- Sabel J.** 1998. *Principles and Parameters of Wh-movement*. Habilitationsschrift, University of Frankfurt.
- Sabel J.** 2002. A minimalist analysis of syntactic islands. *The Linguistics Review* 19: 271–315.
- Stowell T.** 1981. *Origins of Phrase Structure*. Doctoral dissertation, MIT, Cambridge.
- Ura H.** 1996. *Multiple Feature-checking: a Theory of Grammatical Function Splitting*. Doctoral dissertation, MIT, Cambridge.
- Woolford E.** 2000. Agreement in disguise. In: Carstens V & Parkinson F (eds) *Trends in African Linguistics*, 4. Trenton, NJ: Africa World Press, pp 103–117.
- Zeller J.** 2004. Relative clause formation in the Bantu languages of South Africa. *Southern African Linguistics and Applied Language Studies* 22(1&2): 75–93.
- Zeller J.** 2005. Agreement and the EPP in Kinyarwanda applicatives. Unpublished manuscript, University of KwaZulu-Natal, Durban.